

LAMTRAC



1809 Blue Clay Road
Wilmington, NC 28405
910.782.2477
www.SoundHM.com

SPECIFICATIONS

Track Width	17.75 in	450mm
Overall Length (no attachment)	133 in	3378mm
Overall Height	96 in	2438mm
Overall Width	78 in	1981mm
Ground Clearance	14.5 in	368 mm
Weight (no attachment)	14,860 lbs	6,740 kg
Ground Pressure	4.24 psi	29 kPa

ENGINE

Brand/Model/Emissions	Cummins/B4.5/Stage V
Displacement	275 in ³ / 4.5L
Power (@2000 rpm)	155 hp / 115 kw
Torque (@1200 rpm)	525 ft-lb / 712 Nm
DEF Tank Capacity	5 Gal / 18.92L
Engine Compartment lights	1
Fuel Tank Capacity	42.46 Gal / 160.76 L

Hydraulics

Attachment pump size	4.76 in ³ / 78cc
Attachment pump max pressure	6000 PSI / 413.8 BAR
Attachment pump flow	0-44 GPM/0-166.5 L/Min
Description of variable flow capacity	Controlled Electronically
Tank capacity (at full mark)	23.6 Gal/89.3L
Coupler count/size/ratings/style (oringbus)	O-ring Face
Auxiliary pump size	2.69 in ³ / 44 cc
Auxiliary pump flow	25.6 GPM / 96.8L
Hydraulic Compartment lights	1

CAB

Cab certification	ROPS ISO 8082 / FOPS ISO 8083 / OPS ISO 8084
Display details	4.3 in / 110 mm Color
Joystick Sensitivity options	Yes
Pneumatic seat w/Arm adjust	Yes
Electrical outlets	1
USB	2
Cup holder	Yes
Radio	AM/FM/Bluetooth
Exterior light Front	LED Light Bar 14,000 lumens
Exterior light Side	2x850 Lumens
Interior light	Yes
Rear View Camera	7in HD Color Wireless
Cab filtration	Mechanical 50Pa Merv 16 HEPA

Electrical

Voltage	12 VDC
Total battery cranking amp capacity	1500 CCA
Alternator	160A
Wiring	Moduled and seamless
Trouble shooting capability details	Can Bus Provided
Front Attachment Power	8 Pin

Undercarriage

Premium Forestry duty rubber	C Type - 450/86/60
Track Length (in contact with ground)	88in / 2235 mm
Ground Contact area	1562 in ² / 1 m ²
Track width	17.75 in / 450.85 mm
Suspension type	Torflex
Drive motor	2 speed

Options

Winch	Warn Hydraulic 15,000 lbs / 6,800 kg
-------	--------------------------------------



LTR 6160T

Dedicated mulching equipment performance
in a versatile compact package.

1.888.LAMTRAC

© The following are trademarks of Lam trac Global Inc.
© 2021 LAMTRAC Global Inc. All rights reserved.

LAMTRAC.COM

rev. 1.03

LTR 6160T is Lamtrac's third generation in its popular CTL style mulcher carrier. This model features the same industry exclusive features as its predecessors and adds many updates and improvements that clearly make this product the leader in its category.



ENGINE

The heartbeat of LTR 6160T is Cummins latest B4.5, 155HP Stage V diesel engine technology. This engine is not only smaller and lighter, but offers 16% more power, 11% more torque in an EGR free engine than the prior Tier IV alternative. This engine requires no crankcase filter maintenance, offers advanced fuel economy and reduces sound.



HYDRAULICS

Lamtrac's key to success since the launch of the 6000 series tractors has been in the hydraulic system design. Sauer Danfoss components utilized in a closed loop configuration delivers the undisputed highest hydraulic performance in the industry. Professionals know that hydraulic performance is the key to productivity and profitability.

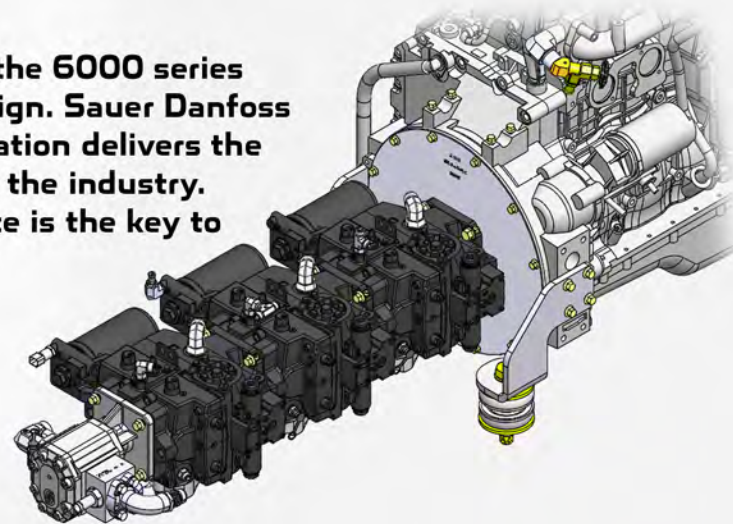

CAB

Easily identified as the most spacious and comfortable operator quarters in this market, the side entry door provides easy and safe access to the cab. Lamtrac's 6160T has pneumatic suspension seat, high definition rear view camera, and new ergonomic joysticks for smooth and comfortable equipment control. This updated cab offers superb peripheral visibility and has the unique feature of being mechanically pressurized to eliminate dust infiltration.



UNDERCARRIAGE

LTR 6160T features a revised track frame with torsion axle suspension to provide a stable and comfortable operation. The high torque gearbox transfers power to the ground and confident travel of the tractor even in the most difficult conditions.



COOLING

Superior cooling capacity is integrated in LTR 6160T. The 3-tiered radiator controls air, engine, and hydraulics temperatures to ensure uninterrupted operation in ambient temperatures exceeding 125F (52c) and prolongs the life of all components and fluids.

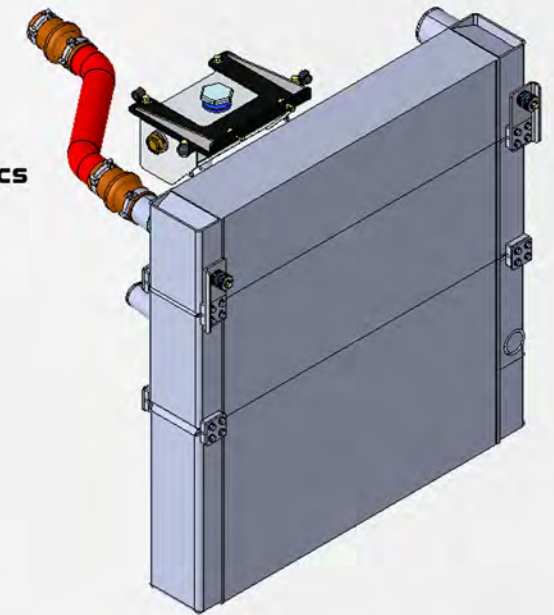

QUICK ATTACH PLATE

While the LTR 6160T was designed to provide the highest hydraulic performance destined primarily land management applications, this robust new design allows this tractor to be host to a wide variety of common attachments to bring versatility and many revenue streams to their owners.

