

KOBELCO

Hydraulic Excavator

-7 SERIES

SK35SR

Performance  Design

■ **Bucket Capacity:**

0.07–0.16 cu.yd. SAE

■ **Engine Power:**

23.1 hp {17.2 kW} @ 2,400 rpm
(SAE NET)

■ **Operating Weight:**

9,000–9,600 lb
{4,080–4,350 kg}



Complies with the
latest exhaust
emission regulations



US EPA
Tier IV Final

Performance Design

PERFORMANCE BY DESIGN

The next generation of KOBELCO excavators brings together superior performance and thoughtful design like never before. Performance enhancements offer greater efficiency and productivity along with increased power and speed. Design improvements provide the ultimate in comfort and control.

KOBELCO refuses to compromise, creating machines that meet every challenge.







EXCEPTIONAL PERFORMANCE JUST GOT EVEN BETTER

Superior Hydraulic System

Our high-quality hydraulic system realizes fast digging cycle time. Furthermore, in synergy with the bucket cylinder, it offers excellent performances without reducing the speed even when a heavy load is applied.

By replacing the bucket cylinder,
the bucket digging force is increased.

»» Bucket Digging Force

Raised by **16%**

(Compared to previous models)

The newly adopted ECO-mode saves
even more energy.

»» Fuel Consumption

Reduced by **24%**

(Compared to H-mode)

Smooth Operation

Our superior hydraulic system contributes to outstanding leveling performance, which makes leveling work easy when heavier attachments are installed.

Integrated-Flow Pump System

During the digging operation, depending upon job condition, the machine provides the additional flow to the boom, arm or bucket circuit, from No.3 pump (swing and dozer pump), to increase available input power to those functions.

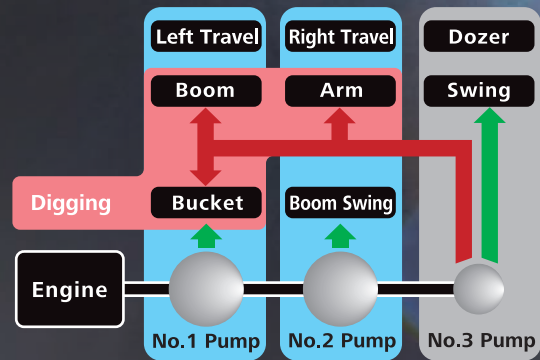

FUNCTIONAL WORK ENVIRONMENT

Designed for operator comfort and convenience.



Color Monitor

The new color monitor shows current and historical operating information in a clear and easy-to-operate format.



Auxiliary Hydraulic Flow

Nibbler/breaker and rotation hydraulic flow has 6 presets that can be adjusted to match your attachment.



Energy Conservation Mode

There are 2 working modes: one for maximum power, and ECO-mode for increased fuel economy.



Auto Deceleration

Auto deceleration saves fuel and lowers engine noise by lowering engine speed to idle.



Maintenance Information



Operation History



Easy-Access Cab

The hinged door is adopted to provide large entrance space. Furthermore, the flip-up left console with integrated pilot control lock lever allows for easy entry and exit from the cab.



Ergonomic Lever Angles

Operators can move levers horizontally without twisting their wrists, reducing fatigue.

Proportional Hand Control for N&B (standard) or Rotation (optional)

Precise proportional controls are integrated into the joystick for ease of operation.



Slide-Open Window

The right side window can slide open from the front or the back for increased ventilation and to hear ground workers when required.



Radio (Bluetooth®, AUX and Hands-Free Phone Calls)



Speaker



12V Power Outlet



Coat Hook



Cup Holder



Utility Box



LED Door Light

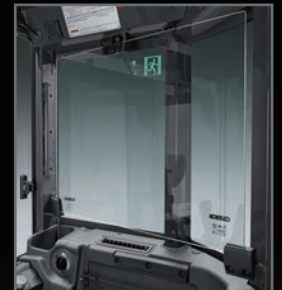

Front Under Glass Holder

UNFORGETTABLE COMFORT

True ergonomic functionality combined with modern design has resulted in a cabin interior that is sleek and comfortable.





Suspension Seat

The newly designed seat comes standard with suspension, recline, forward/back functions giving best-in-class comfort.

Wrist Rests

The larger ergonomic designed wrist rests keep the operator's forearms in a stable position, reducing fatigue, and allowing for improved operation.



Air Conditioner

Multiple air vents to provide uniform airflow to the front and back of the operator as well as to the windows to provide fast defrosting functions.



LED Illumination

Dials and buttons are now backlit to provide a bright, clear view in any lighting condition.



Smartphone Holder/ USB/AUX Port

COMPACT, YET, BIG PERFORMANCE

Compact Boom Swing Radius

6'4" {1,940 mm}

Tail Swing Radius

33.5" {850 mm}

Short Tail Swing

The compact tail swing improves operating efficiency in limited space.

Tail Overhang*

*The rear view mirror is not included in the figures below.

0.0" {0 mm}

(Without additional counterweight)

4.0" {90 mm}

(With additional counterweight)



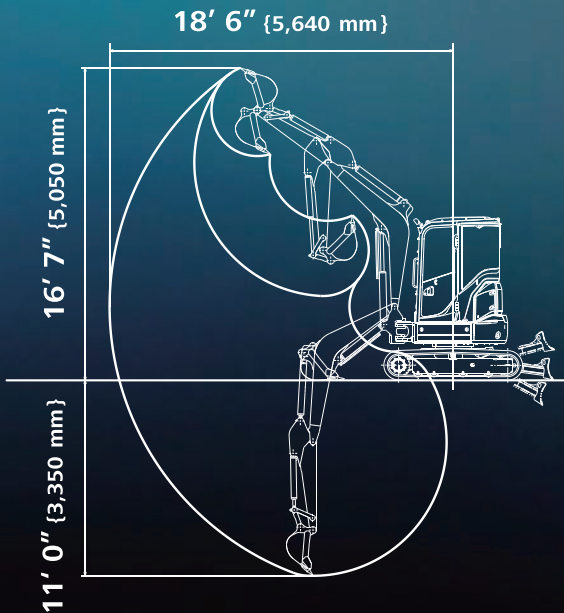

Arm length 5' 6" {1.67 m}

Figures above show the value for cab.

Wide Working Range

Long arms are provided as option equipment to ensure a wide working range.

Easy Transportability

With an overall cab height of 8' 4" {2,550 mm}, the machine is designed for easy transport.



Overall Height 8' 4" {2,550 mm}

VERSATILITY



Dozer Lever

The new ergonomic dozer lever has float integrated into the handle for easier dozer functions.



Dozer-Blade Shape

KOBELCO's unique blade design forms the earth into an arc that always falls forward. Because this prevents earth from falling behind the blade, leveling can be done with less passes.

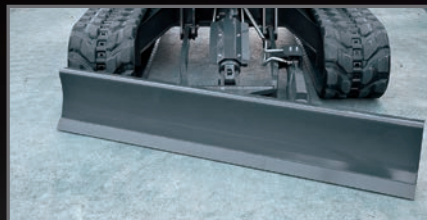
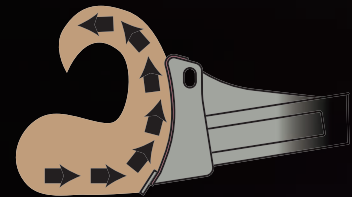

4-Way Blade (optional)

Built-in the same durability as the standard blade, this 4-way option provides 25 to 25 degrees of left and right angle movement for clearing, grading and back-filling. The 4-way dozer gives you better control for following changing terrain.

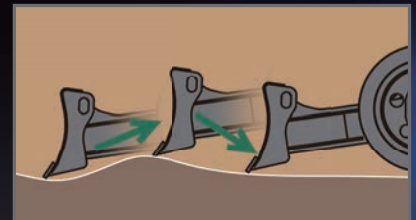

Floating Dozer

Dozer float is standard to assist in easier leveling work.

RELIABLE CONSTRUCTION

The boom, arm and swing bracket all have large cross-section segments for added attachment strength.



Plate Type Pin

Plate type pin retainers prevent wear by rotation of the pin itself. Thick swing bracket.

Forged Boom Top

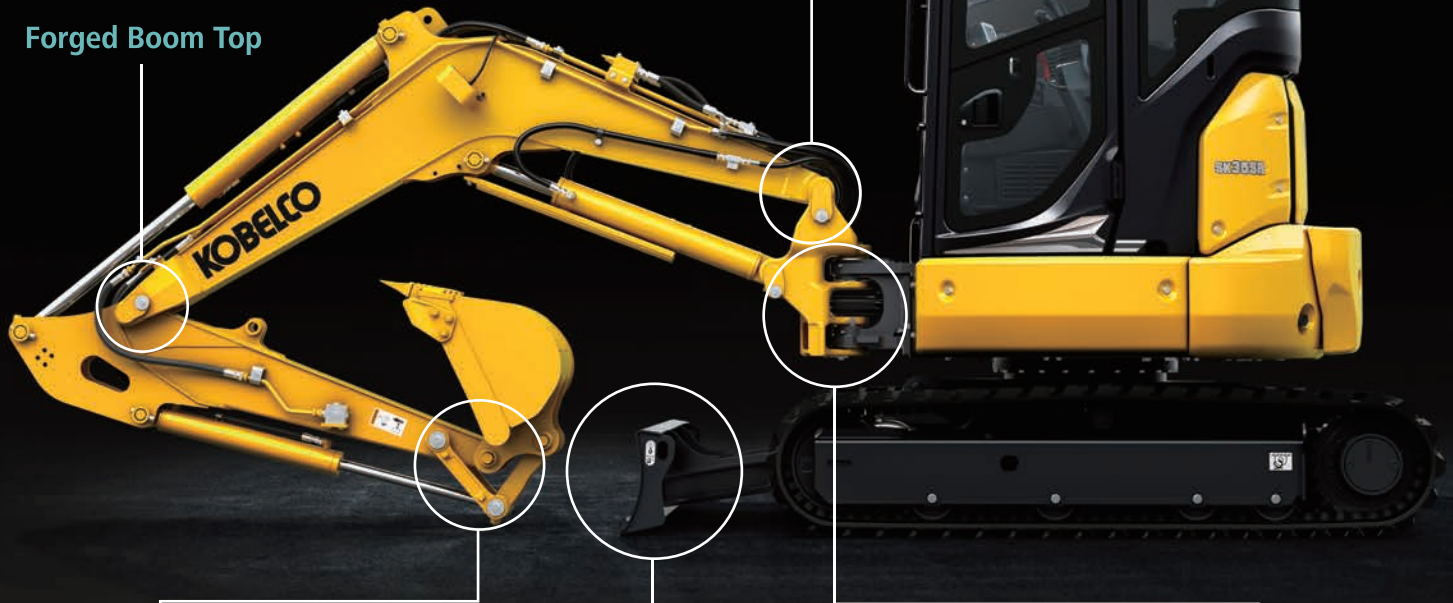

Idler Link

Cast-iron idler links provide greater strength.



Dozer

Box construction dozer supports provide greater strength.



Swing Bracket

Large thick cast-iron swing bracket/front bracket.



Hydraulic Piping

The hydraulic piping is housed inside the swing bracket for protection.

NON-STOP OPERATION BY iNDr

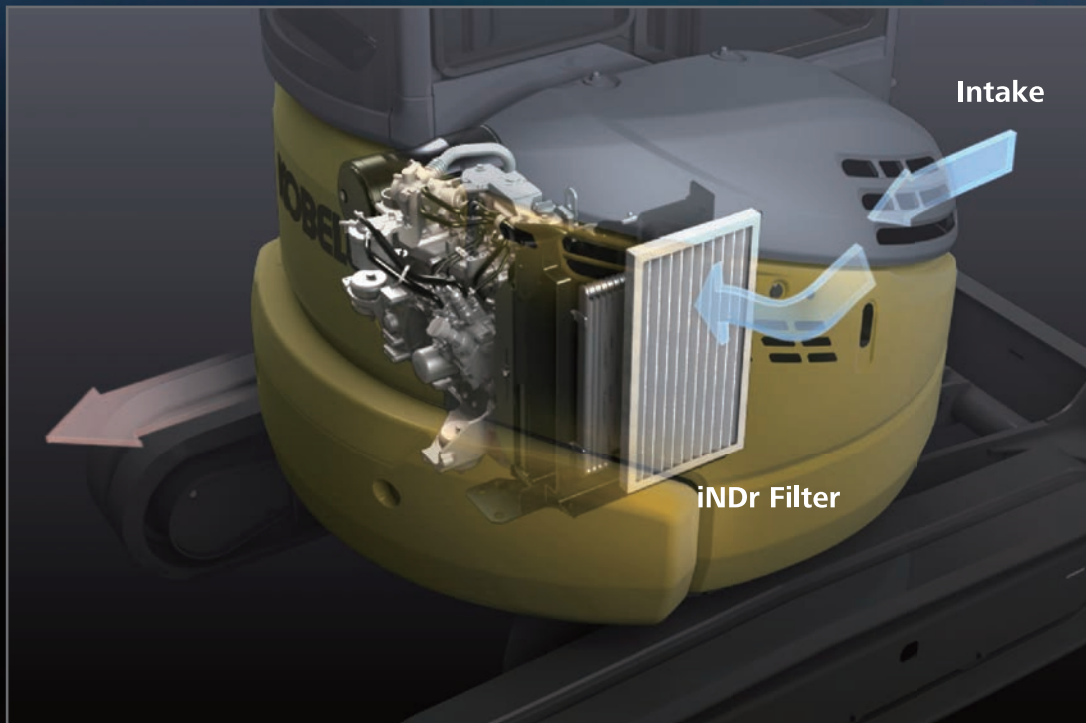

iNDr

A high-density mesh filter blocks dust intruding during air intake. This prevents the cooling device and the air cleaner from clogging with dust and maintains their performances. The ridges of the corrugated filter allow the air to pass through, and the grooves collect the dust, which prevents the filter from clogging.

KOBELCO's exclusive iNDr Cooling System also delivers amazingly quiet operation.

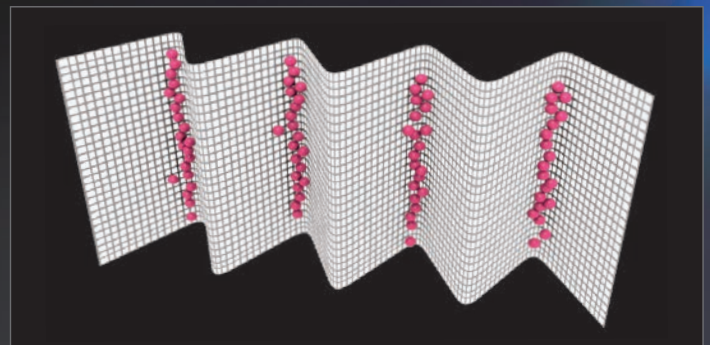

The iNDr filter has a high-density mesh of 30 lines per inch to collect dust.

EASY MAINTENANCE

Easy daily maintenance that saves the trouble of inspection and cleaning.



Easy Access to Component Inside the Cab



Hour Meter



Cab Fresh Air Intake Filter



Cab Re-Circulation Air Filter



Operator Manual Storage Pockets

Easy Access to Cooling Unit



iNDR Filter

Laid out for easy access to radiator and cooling system.

Easy Access to Engine Compartment

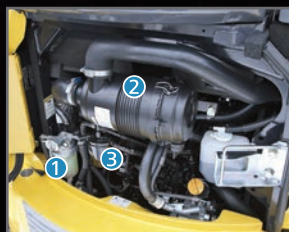

① Pre Fuel Filter with Built-In Water Separator

② Air Cleaner

③ High-Grade Fuel Filter

OPERATOR SAFETY



Robust Cab/Canopy Structure

The high-strength cab/canopy meets ISO 3471:2008, ISO 12117-2:2008 standards for greater operator safety.



Boom Light



Forward and Left-Facing LED Light (Canopy)



Forward and Left-Facing LED Light (Cab)



LED Work Lights

Changed from halogen light to LED light for more brightness. The boom light position has been changed to improve nighttime visibility. New left-facing lights on the cab top and canopy hand rail to improve visibility on the left side of the operator.



Good Visibility

The wiper mount has been moved to the upper right of the cab support and the skylight opening has been enlarged, improving visibility to the front and above.



Rear View Mirror



Hammer for Emergency Exit



Accumulator for Emergency Attachment Lowering

An installed accumulator allows the attachment to be safely lowered to the ground using in-cab controls in the event of an unexpected engine shut-down and class leading smooth operation.

Specifications

Engine

Model	YANMAR 3TNV88F-EPYBD
Type	Direct injection, water-cooled, 4-cycle diesel engine with turbocharger, intercooler, Tier IV Final certified
No. of cylinders	3
Bore and stroke	3.5" × 3.5" {88 mm × 90 mm}
Displacement	100.2 cu.in {1,642 ml}
Rated power output	23.1 hp {17.2 kW}/2,400 rpm (SAE NET) 24.4 hp {18.2 kW}/2,400 rpm (Without fan)
Max. torque	64.8 lb-ft {87.8 N·m}/1,440 rpm (Without fan)

Hydraulic System

Pump	
Type	Two Variable displacement piston pumps + one gear pump
Max. discharge flow	2 × 10.1 gpm {2 × 38.4 L/min} 1 × 5.1 gpm {1 × 19.2 L/min}
Relief valve setting	
Boom, arm and bucket	3,340 psi {23.0 MPa}
Travel circuit	3,340 psi {23.0 MPa}
Swing/Dozer circuit	2,900 psi {20.0 MPa}
Control circuit	510 psi {3.5 MPa}
Pilot control pump	Gear type
Main control valves	10-spool
Oil cooler	Air cooled type

Swing System

Swing motor	One fixed displacement piston motor
Brake	Hydraulic; locking automatically when the swing control lever is in the neutral position
Parking brake	Wet multiple plate
Swing speed	8.2 rpm {8.2 min ⁻¹ }
Swing torque	5,160 lb-ft {7.0 kN·m}

Hydraulic P.T.O.

Specification	Output	Maximum pressure psi {MPa}	Max. flow U.S. gpm, {lpm}
			{0 pressure}
N&B		3,340 {23.0}	2,400 rpm 15.2 {57.6}
Rotary		3,340 {23.0}	5.1 {19.2}

Operating Weight & Ground Pressure

In standard trim, with standard boom, 5'6" {1.67 m} arm, and 0.13 cu.yd. {0.10 m³} ISO heaped bucket

Shaped		Grouser tracks		Rubber tracks	
		Cab	Canopy	Cab	Canopy
Shoe width	ft-in {mm}	11.8" {300}			
Overall width of crawler	ft-in {mm}	5'7" {1,700}			
Ground pressure	psi {kPa}	5.5 {38.1}	5.3 {36.8}	5.4 {37.2}	5.2 {35.8}
Operating weight	lb {kg}	9,600 {4,350}	9,250 {4,200}	9,340 {4,240}	9,000 {4,080}

Travel System

Travel motors	Variable displacement piston, two-speed motors
Travel brakes	Hydraulic brake
Parking brakes	Wet multiple plate
Travel shoes	88 each side
Travel speed	1.6/2.7 mph {2.5/4.4 km/h} (rubber shoe)
	1.5/2.7 mph {2.4/4.3 km/h} (steel shoe)
Drawbar pulling force	8,520 lbs {37.9kN} (Cab)
	8,540 lbs {38.0kN} (Canopy)
Gradeability	58% {30°}

Cab & Control

Cab	All-weather, insulated floor mat.
Control	Two hand levers and two foot pedals for travel Two hand levers for excavating and swing Electric rotary-type engine throttle

Boom, Arm & Bucket

Model	bore × stroke	
	Cab	Canopy
Boom cylinder	3.3" {85 mm} × 22.9" {582 mm}	3.3" {85 mm} × 23.1" {588 mm}
Arm cylinder	3.1" {80 mm} × 26.7" {677 mm}	
Bucket cylinder	2.8" {70 mm} × 20.0" {507 mm}	

Dozer Blade

Dozer cylinder	3.5" {90 mm} × 7.1" {180 mm}
Dimension	5'7" {1,700 mm} (width) × 13.6" {345 mm} (height)
Working range	18.5" {470 mm} (up) × 15.4" {390 mm} (down)

Refilling Capacities & Lubrications

Fuel tank	11.1 U.S.gal {42.0 L}
Cooling system	1.0 U.S.gal {3.8 L}
Engine oil	1.8 U.S.gal {6.7 L}
Travel reduction gear	2 × 0.2 U.S.gal {0.6 L}
Hydraulic oil tank	5.4 U.S.gal {20.4 L}: Tank oil level
	11.8 U.S.gal {44.8 L}: Hydraulic system

Working Ranges

Unit: ft-in {mm}

Model	SK35SR	
	Cab	Canopy
Boom	8'1" {2.47 m}	
Range	Long	
	5'6" {1.67m}	
a- Max. digging reach	18'6" {5,640}	
b- Max. digging reach at ground level	18'0" {5,490}	
c- Max. digging depth	11'0" {3,350}	10'9" {3,270}
d- Max. digging height	16'7" {5,050}	17'2" {5,240}
e- Max. dumping clearance	12'0" {3,670}	12'8" {3,850}
f- Min. dumping clearance	3'4" {1,010}	3'7" {1,100}
g- Max. vertical wall digging depth	9'1" {2,760}	
h- Min. swing radius	7'8" {2,330}	7'3" {2,220}
h'-Min. swing radius at boom swing	6'4" {1,940}	6'0" {1,840}
i- Horizontal digging stroke at ground level	9'5" {2,860}	
j- Digging depth for 8' (2.4 m) flat bottom	9'7" {2,930}	9'5" {2,860}
k- Dozer blade (height/depth)	18.5" {470}/15.4" {390}	

Digging Force (ISO 6015)

Unit: lbs {kN}

Arm length		Long
		5'6" {1.67m}
Bucket digging force	SAE	6,290 {28.0}
	ISO	7,240 {32.2}
Bucket digging force (Two pin bucket)	SAE	8,660 {38.5}
	ISO	9,960 {44.3}
Arm crowding force	SAE	4,200 {18.7}
	ISO	4,380 {19.5}

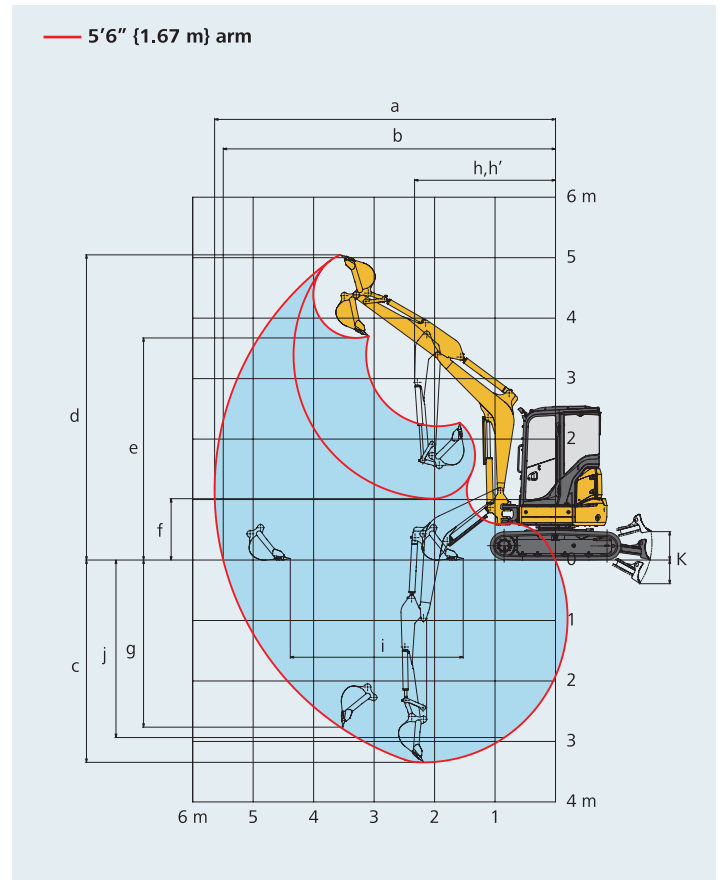

Dimensions

Unit: ft-in {mm}

Arm length		Long
		5'6" {1.67m}
A Overall length		16'0" {4,870}
B Overall height (Cab/Canopy)		8'4" {2,550}/8'3" {2,510}
C Overall width		5'7" {1,700}
D Tail swing radius (less/ Additional weight)		33.5" {850}/37.0" {940}
E Tumbler distance		5'7" {1,700}
F Overall length of crawler		7'1" {2,160}
G Track gauge		4'7" {1,400}
H Shoe width		11.8" {300}

I Ground clearance		9.4" {240}
J Overall width of upperstructure		5'0" {1,530}
K Distance from dozer top to center of upperstructure		5'1" {1,560}
L Boom offset volume (right)		28.5" {725}
M Boom offset volume (left)		28.3" {720}
N Offset volume of boom center		2.0" {50}
O Digging distance outside crawler shoe (right)		6.9" {175}
P Digging distance outside crawler shoe (left)		2.8" {70}
Q Boom swing angle (left /right)		70°/60°

*11.8" {300 mm} Rubber tracks.

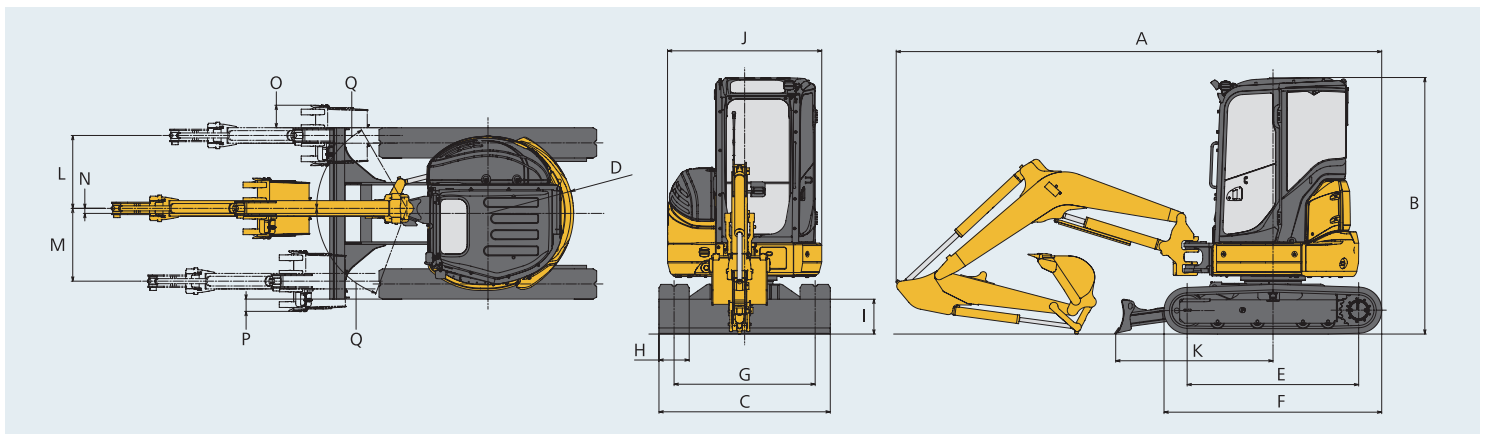

Lift Capacities

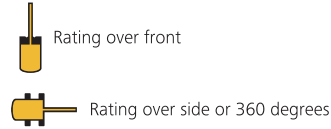
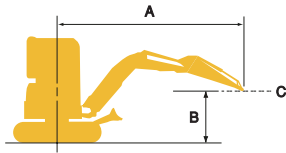

A - Reach from swing centerline for bucket hook
 B - Bucket hook height above/below ground
 C - Lift point
 Relief valve setting : 3,340 psi (23.0 MPa)

SK35SR Cab		Arm: 5'6" {1.67 m} Bucket: Without Shoe: 11.8" {300 mm} Counterweight: Standard counterweight + 550 lb {250 kg} Dozer: Blade down										
A \ B		3'3" {1.0 m}		6'7" {2.0 m}		9'10" {3.0 m}		13'1" {4.0 m}		At max. reach		
												Radius
13'1" {4.0 m}	lb {kg}									*1,590 {720}	*1,590 {720}	12'3" {3.74 m}
9'10" {3.0 m}	lb {kg}							*1,490 {670}	1,470 {660}	*1,540 {690}	1,210 {550}	14'8" {4.47 m}
6'7" {2.0 m}	lb {kg}					*1,930 {870}	*1,930 {870}	*1,670 {760}	1,420 {640}	*1,510 {680}	1,050 {470}	15'10" {4.83 m}
3'3" {1.0 m}	lb {kg}					*2,790 {1,260}	2,050 {930}	*1,990 {900}	1,360 {610}	*1,590 {720}	1,000 {450}	16'1" {4.92 m}
G.L.	lb {kg}			*3,630 {1,640}	3,600 {1,630}	*3,310 {1,500}	1,950 {880}	*2,210 {1,000}	1,310 {590}	*1,760 {800}	1,030 {470}	15'7" {4.75 m}
-3'3" {-1.0 m}	lb {kg}	*4,110 {1,860}	*4,110 {1,860}	*5,890 {2,670}	3,620 {1,640}	*3,260 {1,480}	1,920 {870}	*2,130 {960}	1,300 {590}	*1,850 {840}	1,190 {540}	14'1" {4.29 m}
-6'7" {-2.0 m}	lb {kg}	*6,780 {3,070}	*6,780 {3,070}	*4,240 {1,920}	3,720 {1,690}	*2,430 {1,100}	1,980 {900}			*1,880 {850}	1,680 {760}	11'1" {3.39 m}

SK35SR Canopy		Arm: 5'6" {1.67 m} Bucket: Without Shoe: 11.8" {300 mm} Counterweight: Standard counterweight + 550 lb {250 kg} Dozer: Blade down										
A \ B		3'3" {1.0 m}		6'7" {2.0 m}		9'10" {3.0 m}		13'1" {4.0 m}		At max. reach		
												Radius
13'1" {4.0 m}	lb {kg}									*1,590 {720}	1,560 {710}	12'3" {3.74 m}
9'10" {3.0 m}	lb {kg}							*1,490 {670}	1,410 {640}	*1,540 {690}	1,160 {530}	14'8" {4.47 m}
6'7" {2.0 m}	lb {kg}					*1,930 {870}	*1,930 {870}	*1,670 {760}	1,370 {620}	*1,510 {680}	1,010 {450}	15'10" {4.83 m}
3'3" {1.0 m}	lb {kg}					*2,790 {1,260}	1,970 {890}	*1,990 {900}	1,300 {590}	*1,590 {720}	960 {430}	16'1" {4.92 m}
G.L.	lb {kg}			*3,630 {1,640}	3,450 {1,560}	*3,310 {1,500}	1,870 {850}	*2,210 {1,000}	1,250 {570}	*1,760 {800}	990 {450}	15'7" {4.75 m}
-3'3" {-1.0 m}	lb {kg}	*4,110 {1,860}	*4,110 {1,860}	*5,890 {2,670}	3,480 {1,570}	*3,260 {1,480}	1,850 {840}	*2,130 {960}	1,240 {560}	*1,850 {840}	1,130 {510}	14'1" {4.29 m}
-6'7" {-2.0 m}	lb {kg}	*6,780 {3,070}	*6,780 {3,070}	*4,240 {1,920}	3,580 {1,620}	*2,430 {1,100}	1,900 {860}			*1,880 {850}	1,610 {730}	11'1" {3.39 m}

Note:

- Do not attempt to lift or hold any load that is greater than these lift capacities at their specified lift point radius and heights. Weight of all accessories must be deducted from the above lift capacities.
- Lift capacities are based on machine standing on level, firm, and uniform ground. User must make allowance for job conditions such as soft or uneven ground, out of level conditions, side loads, sudden stopping of loads, hazardous conditions, experience of personnel, etc.
- Bucket pin attachment point defined as lift point.
- The above lift capacities are in compliance with ISO 10567. They do not exceed 87% of hydraulic lift capacity or 75% of tipping load. Lift capacities marked with an asterisk(*) are limited by hydraulic capacity rather than tipping load.
- Operator should be fully acquainted with the Operator's and Maintenance Instructions before operating this machine. Rules for safe operation of equipment should be adhered to at all times.
- Lift capacities apply to only machine as originally manufactured and normally equipped by KOBELCO CONSTRUCTION MACHINERY CO., LTD.

MEMO

Standard and Optional Equipment

● =Std ○ =Opt

Category	Description	SK35SR-7
Engine	YANMAR 3TNV88F (Tier IV Final certified)	●
	Auto deceleration function	●
Hydraulic system	2 work modes H, Eco	●
	Bi-direction (proportional hand control) and single-direction auxiliary hydraulics (nibbler and breaker)	●
	Rotation hydraulics with proportional hand control*	○
	Remote N&B pressure relief adjustment	●
	Hydraulic flow adjustment	●
	Hydraulic oil VG46	●
Cabin	Suspension seat (PVC)	●
	Multi-function color display	●
	LED door light**	●
	Automatic climate control**	●
	Radio (AM/FM, AUX, USB, Bluetooth® and hands-free telephone)**	●
	12V power outlet	●
	3 LED work lights ; 1 on boom, 1 on front, 1 on left	●
Lights	3 LED work lights ; 1 on boom, 1 on front, 1 on left	●
	Standard boom 8'1" (2.47 m)	●
Working equipment	Long arm 5'6" (1.67 m) with thumb bracket	●
	Standard C/W 1,440 lb (660 kg) and Additional bolt on C/W 550 lb (250 kg)	●
Counterweight	Standard C/W 1,440 lb (660 kg) and Additional bolt on C/W 550 lb (250 kg)	●
	11.8" (300 mm) rubber tracks	●
Undercarriage	11.8" (300 mm) double grouser shoe	○
	Dozer blade with float	●
	Angle dozer blade with float*	○
	Lower swivel guard	●
	ROPS compliant canopy (ISO 3471:2008, ISO 12117-2:2008)	●
	ROPS compliant cab (ISO 3471:2008, ISO 12117-2:2008)	○
Safety	Mesh-type front guard for canopy (OPG Level I)	○
	Mesh-type front guard for cab (OPG Level I)	○
	Mesh-type top guard for cab	○
	3-inch retractable seatbelt	○
	Travel alarm	●
	Left rear view mirror	●
	Hose burst valve for boom and arm cylinder	○
	ISO to BHL pattern changer	●
	Arm and bucket cylinder rod guard	○
	Double Air Filter Element	●

*May not be ordered with combination Rotation and Angle dozer blade with float. ** Only for Cab.

4-Way Blade

Unit: ft-in (mm)

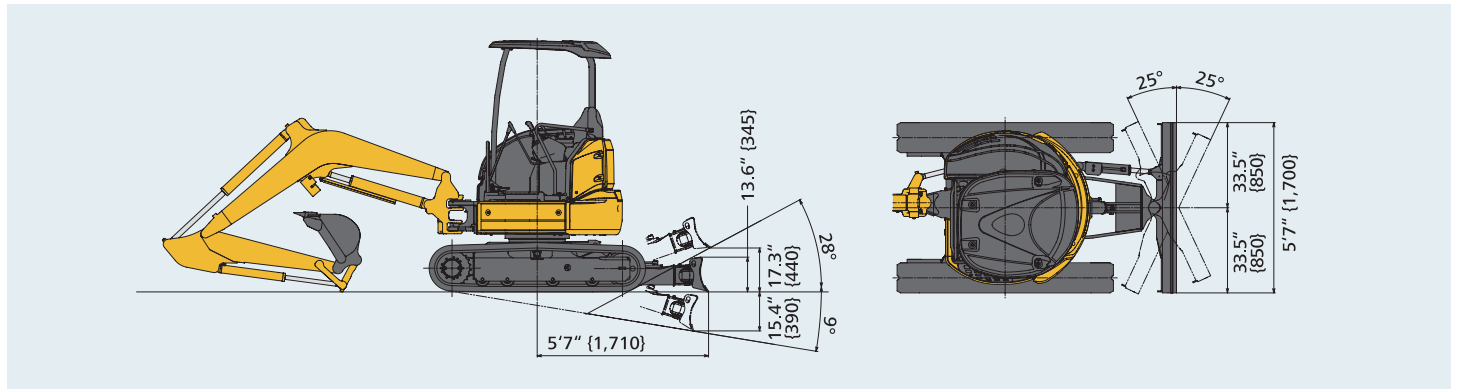

Note: Bluetooth® is a registered trademark of the Bluetooth SIG Inc.

Note: This catalog may contain attachments and optional equipment that are not available in your area. And it may contain photographs of machines with specifications that differ from those of machines sold in your areas. Please consult your nearest KOBELCO distributor for those items you require. Due to our policy of continuous product improvements all designs and specifications are subject to change without advance notice.

Copyright by **KOBELCO CONSTRUCTION MACHINERY CO., LTD.** No part of this catalog may be reproduced in any manner without notice.

KOBELCO CONSTRUCTION MACHINERY U.S.A. INC.

22350 Merchants Way, Katy, TX 77449
Tel: 281-888-8430 Fax: 281-506-8713
www.KOBELCO-USA.com

Inquiries To:

KOBELCO is the corporate mark used by Kobe Steel on a variety of products and in the names of a number of Kobe Steel Group companies.

Bulletin No. SK35SR-7_NA_101_230400N